

CONSTRUCTION NOTES AND REQUIREMENTS

THE FOLLOWING NOTES ARE APPLICABLE TO THE REPAIR OF TRENCHES AND INTERMITTENT UTILITY CUTS IN EXISTING FULL DEPTH FLEXIBLE PAVEMENT.

SEE STANDARD BC 576.19-1 FOR CONSTRUCTION DETAILS.

REMOVE EXISTING PAVEMENT:

EXISTING PAVEMENT SHALL BE REMOVED TO THE DIMENSIONS SHOWN ON THE CONSTRUCTION DETAIL FOR BOTH LONGITUDINAL AND TRANSVERSE PAVEMENT CUTS.

PAVEMENT REPLACEMENT:

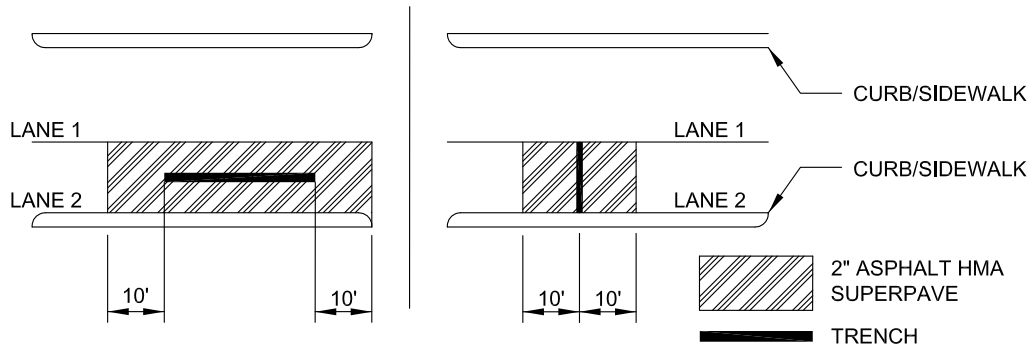

**FIGURE 1
LONGITUDINAL TRENCH**

**FIGURE 2
TRANSVERSE TRENCH**

MILLING AND OVERLAYING SHALL BE USED TO EXTEND THE LIMITS OF THE SURFACE COURSE BEYOND THE LIMITS OF THE FULL DEPTH PATCH IN ACCORDANCE WITH THE FOLLOWING:

A. LONGITUDINAL TRENCHES:

REMOVE THE TOP 2" (INCHES) OF THE EXISTING SURFACE ASPHALT PAVEMENT, BY CLEAN SAW CUT, FOR THE ENTIRE TRAFFIC LANE WIDTH WHERE THE TRENCH IS LOCATED, AND RESURFACE WITH 2" INCHES OF HOT MIX ASPHALT SUPER PAVE 12.5mm. FOR SURFACE COURSE PG64-22, LEVEL 2. ADD AN ADDITIONAL 10 FT. AT THE BEGINNING AND ENDING OF TRENCH. SEE FIGURE 1 ABOVE.

B. TRANSVERSE TRENCH AND INTERMITTENT UTILITY CUT:

REMOVE THE TOP 2" (INCHES) OF THE EXISTING SURFACE ASPHALT PAVEMENT, 10' ON EACH SIDE OF THE TRENCH AND INTERMITTENT UTILITY CUT FOR THE ENTIRE WIDTH OF THE AFFECTED TRAFFIC LANE AND RESURFACE WITH 2" HOT MIX ASPHALT SUPERPAVE 12.5mm FOR SURFACE COURSE PG64-22 LEVEL 2. SEE FIGURE 2 ABOVE.



THE TOP 6 INCHES OF THE TRENCH OR INTERMITTENT UTILITY CUT SHALL BE FILLED WITH COMPACTED SUBBASE (6 INCHES CRUSHER RUN AGGREGATE, CR-6). ADDITIONAL SUBBASE THICKNESS, IF REQUIRED, SHALL BE IN ACCORDANCE WITH THE PLANS OR AS DIRECTED BY THE ENGINEER. SEE 32-11-23.10 IN SPECIFICATIONS.

COMPACT SUBBASE OF ENTIRE OPENING BEFORE PLACING HOT MIX ASPHALT. THE FLEXIBLE PAVING SHALL BE REPLACED FLUSH WITH THE FINISHED PAVEMENT SURFACE USING A BASE COURSE WITH MAXIMUM 3 INCH COMPACTED LAYERS AND A 2 INCH COMPACTED SURFACE COURSE. SEE 32-01-30.10, 3.6.A.2.b IN SPECIFICATIONS.

ALL EXPOSED EDGES OF EXISTING FLEXIBLE PAVEMENT, THE SURFACE OF THE SUBBASE AND EACH LAYER OF HOT MIX ASPHALT SHALL BE TACK COATED IN ACCORDANCE WITH THE AFOREMENTIONED SPECIFICATIONS BEFORE THE NEXT LAYER OF HOT MIX ASPHALT IS PLACED.

GENERAL NOTES:

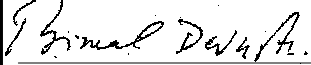
ALL WORK TO BE PERFORMED IN ACCORDANCE WITH THE LATEST BALTIMORE CITY STANDARD SPECIFICATIONS. PROCEDURE FOR MAINTENANCE OF TRAFFIC SHALL BE APPROVED BY THE DEPARTMENT OF TRANSPORTATION (DOT) BEFORE ANY EXISTING PAVEMENT IS REMOVED.

	APPROVED:  DIVISION CHIEF, TRANSPORTATION ENGINEERING AND CONSTRUCTION  DIRECTOR, DEPARTMENT OF TRANSPORTATION	CITY OF BALTIMORE DEPARTMENT OF TRANSPORTATION TRANSPORTATION ENGINEERING AND CONSTRUCTION	ISSUED 8 / 2010	REVISED	REVISED
	STREET CUT AND REPAIR FULL DEPTH FLEXIBLE PAVEMENT	STANDARD NO. BC 576.19-2			
		SCALE : NONE	SHEET 2 OF 2		